

# **Table of Contents**

## **GARDSERTS™**

**GARDSERTS™ Feature:  
Self-Tapping • Self-Cutting • Self-Locking  
Won't Pull Out • Won't Wear Out**

<b>GARDSERT™ Applications by Industry</b> .....	<b>2</b>
<b>Installations</b> .....	<b>3-4</b>
<b>Fractional</b> .....	<b>5-7</b>
<b>Fractional Assortments</b> .....	<b>8-9</b>
<b>Metric</b> .....	<b>10-12</b>
<b>Metric Assortments</b> .....	<b>12</b>
<b>Installation - Large Diameter</b> .....	<b>13</b>
<b>8 Thread GARDSERTS™</b> .....	<b>14</b>
<b>Pipe Thread</b> .....	<b>15-16</b>
<b>Spark Plug/O<sup>2</sup> Sensor</b> .....	<b>17-18</b>
<b>EMD Engine Turbo (rear) GARDSERT™ Repair</b> .....	<b>19</b>
<b>EMD Engine GARDSERT™ Block Repair</b> .....	<b>19</b>
<b>GARD PIPESERT™ Engine Installation</b> .....	<b>20</b>
<b>Brass - Wood / Plastic</b> .....	<b>21</b>
<b>Drill Sets for GARDSERTS™</b> .....	<b>22</b>
<b>Installation Tools</b> .....	<b>23-24</b>
<b>Technical Data</b> .....	<b>25-27</b>
<b>Airport Runway Lighting</b> <b>Base Can Top Flange Repair Kit</b> .....	<b>28-31</b>



**Buy American Act  
GARDSERTS™ are Made in the U.S.A.**



## **GARDSERTS™ by Industry**

### **AUTOMOTIVE INDUSTRY**

**REPAIR:** Spark Plug, O<sup>2</sup> Sensor, Brake Calliper, Transmission, Bell Housing, Cylinder Head, Engine Block

**MANUFACTURING:** Machine Tools, Pedestrian Guards (attach plexi-glass to metal rail), Heat Treat Oven Door Hinges, Dynamometer, Stamping Machine Components, Robotic Arm Screw Adjustment

### **RAIL / MARINE**

**REPAIR:** Engines - E.M.D. (custom assortment Part No. 200-EMD, contact GARD for details) Caterpillar, Cummins, Detroit and various foreign manufacturers. Fuel Injection Pump, Powertrain, Hull Fittings, Traction Motor, Brake System, Generator/Alternator, Suspension/Frame components

### **PLASTIC / POLYMERS**

Molding Platens, Injection Molding, Extrusion Die, Cutter Bar Assembly, Strengthen Plastic Assemblies with Brass **GARDSERTS™**

### **AIRPORT**

FAA approved Base Can Light Repair (custom assortment Part No. 200-AW7012G, ask your representative for details)

### **MANUFACTURING**

**REPAIR:** Guide Bars and Brackets, Fixtures, Machine Tools, Drum Dryers

### **POWER / ENERGY**

G.E. Turbines - Custom 8 Thread pitch are available; contact **GARD** for details. Turbine Housing Repair, Generators, Pumps

### **HEAVY EQUIPMENT**

Engine, Transmission, Drive Line, Chassis Components, Hydraulic Pump, Fuel Injection Pumps

### **RUBBER / TIRE**

Mold Rings, Tread Mold, Cutter Bar/Grinders

### **MILITARY**

Auxiliary Equipment approved (see all applications above) Coast Guard Approved, TACOM approved; all wheel and tracked vehicles, Stryker LAV, Bradley Fighting, etc., (excludes Abrams). National Stock Number assignment (custom assortment Part No. MGA-412614-TDA, contact your **GARD** representative for details). ABS Approved - SBA, Veteran Owned

If you have a new application for **GARDSERTS™**, please let us know!

## GARDSERT™ Installations

GARDSERTS™ are to be considered a permanent repair of damaged threads without pull-out or wear-out.

GARDSERTS™ are self-tapping and require no special tools.

GARDSERTS™ are made of Steel or Stainless Steel (depending on your selection).

GARDSERTS™ have the pull-out strength that is more than double that of a Grade 8 bolt.

### MANUAL INSTALLATION

You will need: the appropriate drill bit (**note: When installing in 6000 Series Aluminum - use Steel size drill bit**), hex nut, wrenches and hardened bolt for the GARDSERT™.

- 1) Drill out damaged threads (reference drill chart included with each shipment).
- 2) Turn hex nut onto cap screw, follow by threading the **GARDSERT™** onto the cap screw, and be sure to keep the cutting holes open.
- 3) Carefully align the **GARDSERT™** to the hole and turn into the hole clockwise using a wrench on the hex nut. Bottom out assembly on the work piece. Hold the cap screw and loosen the hex nut, turning counter-clockwise. You now have a completely threaded hole and a solid repair.

Cap screw length



Hex nut, same thread as internal thread of the GARDSERT™



## GARDSERT™ Installations

### AIR TOOL INSTALLATION

You will need: Your air tool and wrench. The appropriate drill bit (**note: When installing in 6000 Series Aluminum - use Steel size drill bit**), oversized hex nut, oversized flat washers and hardened bolt for the **GARDSERT™**.

- 1) Drill out damaged threads (reference drill chart included with each shipment).
- 2) Obtain a cap screw matching the internal thread of the **GARDSERT™**. Assemble unit virtually as shown. (1) flat washer, (1) oversized nut, (1-2) flat washers, finishing with the **GARDSERT™**.
- 3) Carefully align the **GARDSERT™** to the hole, drive in by putting the socket of the air tool on the cap screw head. Bottom out assembly on the work piece. Place spanner wrench on oversized nut and secure it. Reverse air tool to break assembly loose. You now have a completely threaded hole and a solid repair.

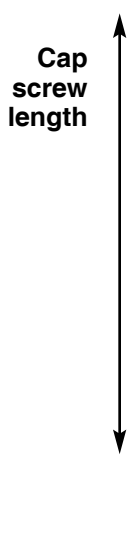

- (1) appropriate size F-911 cap screw
- (1) oversized hex nut
- (2) flat washers
- GARDSERT™



## Hardened Steel GARDSERTS™

**SIZE: Fractional**

**MATERIAL: Hardened Steel**

**WALL: Standard**



Internal Thread Size and Pitch	GARDSERT™ Part No.	Length	External Diameter and Threads Per Inch	Steel, Cast Iron, 6000 Series Alum. Drill Size (Part No.)	Aluminum Non-Ferrous** Drill Size (Part No.)		
#2- 56 #2- 64	256-200 264-200	0.188	9/64-48	#30 (Part No. 34-30)	#30 (Part No. 34-30)		
#4- 40 #4- 48	440-200 448-200	0.234	11/64-40	#20 (Part No. 34-20)	#21 (Part No. 34-21)		
#6- 32 #6- 40	632-200 640-200	0.281	7/32-32	#4 (Part No. 34-4)	#5 (Part No. 34-5)		
#8- 32 #8- 36	832-200 836-200	0.328	1/4-32	"B" (Part No. 34-B)	15/64" (Part No. 30-038)		
#10- 24 #10- 32	1024-200 1032-200	0.375	19/64-24	"J" (Part No. 34-J)	"I" (Part No. 34-I)		
1/4-20 1/4-28	C-400-200 F-400-200	0.484	3/8-20	23/64" (Part No. 30-058)	"S" (Part No. 34-S)		
5/16-18 5/16-24	C-500-200 F-500-200	0.562	15/32-18	29/64" (Part No. 30-073)	7/16" (Part No. 30-07)		
3/8-16 3/8-16 (M) 3/8-24	C-600-200 C-600-200M F-600-200	0.687 0.562 0.687	9/16-16	17/32" (Part No. 30-085)	17/32" (Part No. 30-085)		
7/16-14 7/16-20	C-700-200 F-700-200	0.781	41/64-14	39/64" (Part No. 30-098)	19/32" (Part No. 30-095)		
1/2-13 (S) 1/2-13 (M) 1/2-13	C-800-200S C-800-200M C-800-200	0.562 0.750 0.906	47/64-13	45/64" (Part No. 30-113)	11/16" (Part No. 30-11)		
1/2-20 1/2-20 (M)	F-800-200 F-800-200M	0.906 0.750					
9/16-12 9/16-18	C-900-200 F-900-200	1.0				25/32" (Part No. 30-125)	49/64" (Part No. 30-123)
5/8-11 5/8-18 5/8-18 (M)	C-1000-200 F-1000-200 F-1000-200M	.9375 1.125 0.9375				29/32-11	55/64" (Part No. 30-138)
3/4-10 3/4-16 3/4-16 (M) 3/4-16 (S)	C-1200-200 F-1200-200 F-1200-200M F-1200-200S	1.125 1.375 1.125 0.812	1-5/64-10	1-1/32" (Part No. 30-165)	1-1/64" (Part No. 30-163)		

7/8 to 1-1/2 and 22 MM through 30MM - see the following page(s)  
 \*\*When installing in 6000 Series Aluminum - use steel size drill bit  
 The use of GARD Deluxe Tapping Fluid when installing is strongly recommended.

Assortments are listed on page(s) 8-9  
 Note: Internal and External dimensions are for reference only





## Stainless Steel GARDSERTS™

**SIZE: Fractional**

**MATERIAL: Stainless Steel**

**WALL: Standard**



Internal Thread Size and Pitch	GARDSERT™ Part No.	Length	External Diameter and Threads Per Inch	Steel, Cast Iron, 6000 Series Alum. Drill Size (Part No.)	Aluminum Non-Ferrous** Drill Size (Part No.)
#10- 24	1024-200SS*	0.375	19/64-24	"J" (Part No. 34-J)	"I" (Part No. 34-I)
#10- 32	1032-200SS*				
1/4-20	C-400-200SS*	0.48	3/8-20	23/64" (Part No. 30-058)	"S" (Part No. 34-S)
1/4-28	F-400-200SS*				
5/16-18	C-500-200SS*	0.56	15/32-18	29/64" (Part No. 30-073)	7/16" (Part No. 30-07)
5/16-24	F-500-200SS*				
3/8-16	C-600-200SS*	0.69	9/16-16	17/32" (Part No. 30-085)	17/32" (Part No. 30-085)
3/8-24	F-600-200SS*				
7/16-14	C-700-200SS*	0.78	41/64-14	39/64" (Part No. 30-098)	19/32" (Part No. 30-095)
7/16-20	F-700-200SS*				
1/2-13	C-800-200SS*	0.91	47/64-13	45/64" (Part No. 30-113)	11/16" (Part No. 30-11)
1/2-20	F-800-200SS*				
9/16-12	C-900-200SS*	1.0	13/16-12	25/32" (Part No. 30-125)	49/64" (Part No. 30-123)
9/16-18	F-900-200SS*				
5/8-11	C-1000-200SS*	1.13	29/32-11	55/64" (Part No. 30-138)	55/64" (Part No. 30-138)
5/8-18	F-1000-200SS				
3/4-10	C-1200-200SS*	1.38	1- 5/64-10	1-1/32" (Part No. 30-165)	1-1/64" (Part No. 30-163)
3/4-16	F-1200-200SS*				

Larger sizes listed on page 13.

The use of GARD Deluxe Tapping Fluid is REQUIRED. Part No. 5906-DTF-8

Assortments are listed on page 9.

Note: Internal and External dimensions are for reference only.



**Stainless Steel GARDSERTS™**

**SIZE: Fractional**

**MATERIAL: Stainless Steel**

**WALL: Thin Wall**



Internal Thread Size and Pitch	GARDSERT™ Part No.	Length	External Diameter and Threads Per Inch	Steel, Cast Iron, 6000 Series Alum. Drill Size (Part No.)	Aluminum Non-Ferrous** Drill Size (Part No.)
#10-24	1024-200TW*	0.375	17/64-32	1/4" (Part No. 30-04)	"D" (Part No. 34-D)
#10-32	1032-200TW*	0.375			
1/4-20	C-400-200TW*	0.48	11/32-28	21/64" (Part No. 30-053)	"P" (Part No. 34-P)
1/4-28	F-400-200TW*	0.48			
5/16-18	C-500-200TW*	0.56	13/32-24	"W" (Part No. 34-W)	"V" (Part No. 34-V)
5/16-24	F-500-200TW*	0.56			
3/8-16	C-600-200TW*	0.69	1/2-20	15/32" (Part No. 30-075)	15/32" (Part No. 30-075)
3/8-24	F-600-200TW*	0.69			
7/16-14	C-700-200TW*	0.78	9/16-18	17/32" (Part No. 30-085)	17/32" (Part No. 30-085)
7/16-20	F-700-200TW*	0.78			
1/2-13	C-800-200TW*	0.91	5/8-18	19/32" (Part No. 30-095)	19/32" (Part No. 30-095)
1/2-20	F-800-200TW*	0.91			

**\*Hardened Stainless Steel**

The use of GARD Deluxe Tapping Fluid is REQUIRED. Part No. 5906-DTF-8

Assortments are listed on page 9.

Note: Internal and External dimensions are for reference only.

## GARDSERT™ Assortments

### GARDSERT™ Fractional Assortment Key

- STEEL: Standard Wall**
- STAINLESS STEEL: Standard Wall**
- STAINLESS STEEL: Thin Wall**



ASSORTMENT PART NO.		#6-32	#8-32	#10-24	#10-32	1/4-20	1/4-28	5/16-18	5/16-24	3/8-16	3/8-24	7/16-14	7/16-20	1/2-13	1/2-20	9/16-12	9/16-18	5/8-11	5/8-18	3/4-10	3/4-16	
		Qty.	12	12	12	12	12	12	12	12	12	12	12	12	12	12	6	6	6	6	6	6
#6- 32 thru 3/8"	200-606CL	•	•	•	•	•		•		•												
	200-606FL	•	•	•	•		•		•		•											
	200-606CFL	•	•	•	•	•	•	•	•	•	•											
#6- 32 thru 1/2"	200-608CL	•	•	•	•	•		•		•		•		•								
	200-608FL	•	•	•	•		•		•		•		•		•							
	200-608CFL	•	•	•	•	•	•	•	•	•	•	•	•	•	•	•						
#6- 32 thru 3/4"	200-612CL	•	•	•	•	•		•		•		•		•		•		•		•		•
	200-612FL	•	•	•	•		•		•		•		•		•		•		•		•	•
	200-612CFL	•	•	•	•	•	•	•	•	•	•	•	•	•	•	•	•	•	•	•	•	•

- C= Coarse Thread (USS)
- F= Fine Thread (SAE)
- D= Add the letter D to assortment part number and get GARD MTS™ drill bits for given sizes (Steel & Aluminum installations)
- Eliminate the letter L for half package quantity

**Packed in heavy duty steel tray and includes complete installation instructions.**

Tray Dimensions: 3"H x 18"W x 12"D





## GARDSERT™ Assortments (cont.)

### GARDSERT™ Fractional Assortment Key

- STEEL: Standard Wall**
- STAINLESS STEEL: Standard Wall**
- STAINLESS STEEL: Thin Wall**

C= Coarse Thread (USS)

F= Fine Thread (SAE)

D= Add the letter D to assortment part number and get GARD MTS™ drill bits for given sizes (Steel & Aluminum installations)

Eliminate the letter L for half package quantity

**Packed in heavy duty steel tray and includes complete installation instructions.**

Tray Dimensions: 3"H x 18"W x 12"D



ASSORTMENT PART NO.		#6-32	#8-32	#10-24	#10-32	1/4-20	1/4-28	5/16-18	5/16-24	3/8-16	3/8-24	7/16-14	7/16-20	1/2-13	1/2-20	9/16-12	9/16-18	5/8-11	5/8-18	3/4-10	3/4-16	
		Qty.	12	12	12	12	12	12	12	12	12	12	12	12	12	12	6	6	6	6	6	6
1/4" thru 1/2"	200-408CL					•		•		•		•		•								
	200SS-408CL					•		•		•		•		•								
	200TW-408CL					•		•		•		•		•								
	200-408FL						•		•		•		•		•							
	200SS-408FL						•		•		•		•		•							
	200TW-408FL						•		•		•		•		•							
	200-408CFL					•	•	•	•	•	•	•	•	•	•	•						
	200SS-408CFL					•	•	•	•	•	•	•	•	•	•	•						
	200TW-408CFL					•	•	•	•	•	•	•	•	•	•	•						
1/4" thru 3/4"	200-412CL					•		•		•		•		•		•		•		•		
	200SS-412CL					•		•		•		•		•		•		•		•		
	200-412FL						•		•		•		•		•		•		•		•	
	200SS-412FL						•		•		•		•		•		•		•		•	
	200-412CFL					•	•	•	•	•	•	•	•	•	•	•	•	•	•	•	•	•
	200SS-412CFL					•	•	•	•	•	•	•	•	•	•	•	•	•	•	•	•	•



## Steel GARDSERTS™

**SIZE: Metric**  
**MATERIAL: Steel**  
**WALL: Standard**



Internal Thread Size and Pitch	GARDSERT™ Part No.	Length	External Diameter and Threads Per Inch	Steel, Cast Iron, 6000 Series Alum. Drill Size (Part No.)	Aluminum Non-Ferrous** Drill Size (Part No.)
M2 X .4	<b>M2-200</b>	0.188	9/64-48	<b>#30</b> (Part No. 34-30)	<b>#30</b> (Part No. 34-30)
M2.5 X .45	<b>M2.5-200</b>	0.234	11/64-40	<b>#20</b> (Part No. 34-20)	<b>#21</b> (Part No. 34-21)
M2.6 X .45	<b>M2.6-200</b>	0.234	11/64-40	<b>#20</b> (Part No. 34-20)	<b>#21</b> (Part No. 34-21)
M3 X .5	<b>M3-200</b>	0.234	11/64-40	<b>#20</b> (Part No. 34-20)	<b>#21</b> (Part No. 34-21)
M3.5 X .6	<b>M3.5-200</b>	0.281	7/32-32	<b>#4</b> (Part No. 34-4)	<b>#5</b> (Part No. 34-5)
M4 X .7	<b>M4-200</b>	0.328	1/4-32	<b>"B"</b> (Part No. 34-B)	<b>15/64"</b> (Part No. 30-038)
M5 X .8	<b>M5-200</b>	0.375	19/64-24	<b>"J"</b> (Part No. 34-J)	<b>"I"</b> (Part No. 34-I)
M6 X 1.0	<b>M6-200</b>	0.484	3/8-20	<b>23/64"</b> (Part No. 30-058)	<b>"S"</b> (Part No. 34-S)
M8 X 1.25	<b>M8-200</b>	0.562	15/32-18	<b>29/64"</b> (Part No. 30-073)	<b>7/16"</b> (Part No. 30-07)
M10 X 1.5	<b>M10-200</b>	0.687	9/16-16	<b>17/32"</b> (Part No. 30-085)	<b>17/32"</b> (Part No. 30-085)
M12 X 1.50	<b>M12.5-200</b>	0.906	47/64-13	<b>45/64"</b> (Part No. 30-113)	<b>11/16"</b> (Part No. 30-11)
M12 X 1.75	<b>M12-200</b>	0.906	47/64-13	<b>45/64"</b> (Part No. 30-113)	<b>11/16"</b> (Part No. 30-11)
M14 X 2.0	<b>M14-200</b>	1.000	13/16-20	<b>25/32"</b> (Part No. 30-125)	<b>49/64"</b> (Part No. 30-123)
M16 X 2	<b>M16-200</b>	.9375	29/32-11	<b>55/64"</b> (Part No. 30-138)	<b>55/64"</b> (Part No. 30-138)
M18 X 2.5	<b>M18-200</b>	1.375	1- 5/64 -10	<b>1-1/32"</b> (Part No. 30-165)	<b>1-1/64"</b> (Part No. 30-163)
M20 X 2.5	<b>M20-200*</b>	1.1875	1- 5/64 -10	<b>1-1/32"</b> (Part No. 30-165)	<b>1-1/64"</b> (Part No. 30-163)
M22 X 2.5	<b>M22-200*</b>	1.3125	1-1/4 -10	<b>1-7/32"</b> (Part No. 30-195)	
M24 X 3.0	<b>M24-200*</b>	1.500	1-1/2 -8	<b>1-7/16"</b> (Part No. 30-23)	
M30 X 3.5	<b>M30-200*</b>	1.625	1-3/4 -8	<b>1-11/16"</b> (Part No. 5241-27-12)	

\*\*When installing in 6000 Series Aluminum - use Steel size drill bit

\*Hardened Stainless Steel

The use of GARD Deluxe Tapping Fluid is highly recommended. Part No. 5906-DTF-8

Note: Internal and External dimensions are for reference only

Assortments are listed on page 12

## Coarse and Metric Thread Combo Assortment in 20 Compartment Steel Tray

**Part No. 200-CM - Standard Wall, Steel**

**6 pcs. each: 1/4, 5/16, 3/8, 7/16, 1/2,**

**3 pcs. each: 9/16, 5/8, 3/4**

**6 pcs. each: M3, M3.5, M4, M5, M6, M8, M10, M12**

**3 pcs. each: M14, M16, M18**

## Stainless Steel GARDSERTS™



**SIZE: Metric**

**MATERIAL: Hardened Stainless Steel**

**WALL: Standard Wall**

Internal Thread Size and Pitch	GARDSERT™ Part No.	Length	External Diameter and Threads Per Inch	Steel, Cast Iron, 6000 Series Alum. Drill Size (Part No.)	Aluminum Non-Ferrous** Drill Size (Part No.)
M5 X .8	<b>M5-200SS*</b>	0.375	19/64-24	"J" (Part No. 34-J)	"I" (Part No. 34-I)
M6 X 1.0	<b>M6-200SS*</b>	0.484	3/8-20	<b>23/64"</b> (Part No. 30-058)	<b>"S"</b> (Part No. 34-S)
M8 X 1.25	<b>M8-200SS*</b>	0.562	15/32-18	<b>29/64"</b> (Part No. 30-073)	<b>7/16"</b> (Part No. 30-07)
M10 X 1.5	<b>M10-200SS*</b>	0.687	9/16-16	<b>17/32"</b> (Part No. 30-085)	<b>17/32"</b> (Part No. 30-085)
M12 X 1.75	<b>M12-200SS*</b>	0.906	47/64-13	<b>45/64"</b> (Part No. 30-113)	<b>11/16"</b> (Part No. 30-11)
M14 X 2.0	<b>M14-200SS*</b>	1.000	13/16-20	<b>25/32"</b> (Part No. 30-125)	<b>49/64"</b> (Part No. 30-123)
M16 X 2	<b>M16-200SS*</b>	1.125	29/32-11	<b>55/64"</b> (Part No. 30-138)	<b>55/64"</b> (Part No. 30-138)
M18 X 2.5	<b>M18-200SS*</b>	1.375	1-5/64-10	<b>1-1/32"</b> (Part No. 30-165)	<b>1-1/64"</b> (Part No. 30-163)
M20 X 2.5	<b>M20-200*</b>	1.1875	1-5/64-10	<b>1-1/32"</b> (Part No. 30-165)	<b>1-1/64"</b> (Part No. 30-163)
M22 X 2.5	<b>M22-200*</b>	1.3125	1-1/4-10	<b>1-7/32"</b> (Part No. 30-195)	
M24 X 3.0	<b>M24-200*</b>	1.5000	1-1/2-8	<b>1-7/16"</b> (Part No. 30-23)	
M30 X 3.5	<b>M30-200*</b>	1.6250	1-3/4-8	<b>1-11/16"</b> (Part No. 5241-27-12)	

**\*\*When installing in 6000 Series Aluminum - use Steel size drill bit**

**\*Hardened Stainless Steel**

**The use of GARD Deluxe Tapping Fluid is REQUIRED. Part No. 5906-DTF-8**

**Assortments are listed on page 12**

**Note: Internal and External dimensions are for reference only**



# Stainless Steel GARDSERTS™

SIZE: Metric

MATERIAL: Hardened Stainless Steel

WALL: Thin Wall



Internal Thread Size and Pitch	GARDSERT™ Part No.	Length	External Diam. and Threads Per Inch	Steel, Cast Iron, 6000 Series Alum. Drill Size (Part No.)	Aluminum Non-Ferrous** Drill Size (Part No.)
M5 X .8	M5-200TW*	.375	17/64-32	1/4" (Part No. 30-04)	"D" (Part No. 34-D)
M6 X 1.0	M6-200TW*	.484	11/32-28	21/64" (Part No. 30-053)	"P" (Part No. 34-P)
M8 X 1.25	M8-200TW*	.562	13/32-24	"W" (Part No. 34-W)	"V" (Part No. 34-V)
M10 X 1.25	M101.25-200TW*	.687	1/2-20	15/32" (Part No. 30-075)	15/32" (Part No. 30-075)
M10 X 1.5	M10-200TW*	.687	1/2-20	15/32" (Part No. 30-075)	15/32" (Part No. 30-075)
M11 X 1.25	M11X 1.25-200TW*	.781	9/16-18	17/32" (Part No. 30-085)	17/32" (Part No. 30-085)
M11 X 1.50	M11 X 1.50-200TW*	.781	9/16-18	17/32" (Part No. 30-085)	17/32" (Part No. 30-085)
M11 X 2.00	M11 X 2.00-200TW*	.781	9/16-18	17/32" (Part No. 30-085)	17/32" (Part No. 30-085)
M12 X 1.75	M12-200TW*	.906	5/8-18	19/32" (Part No. 30-095)	19/32" (Part No. 30-095)

\*\*When installing in 6000 Series Aluminum use Steel size drill bit

\*Hardened Stainless Steel  
The use of GARD Deluxe Tapping Fluid is **REQUIRED**.  
Part No. 5906-DTF-8

### GARDSERT™ METRIC Assortment Key

- STEEL: Standard Wall
- STAINLESS STEEL: Standard Wall
- STAINLESS STEEL: Thin Wall

### GARDSERT™ Assortments

REGULAR WALL	ASSORTMENT PART NO.	Qty.	M3 X .5	M3.5 X .6	M4 X .7	M5 X .8	M6 X 1.0	M8 X 1.25	M10 X 1.5	M12 X 1.75	M14 X 2.0	M16 X 2.0	M18 X 2.5
			12	12	12	12	12	12	12	12	6	6	6
3 MM thru 18 MM	200M-318L		•	•	•	•	•	•	•	•	•	•	•
5 MM thru 18 MM	200MSS-518L					•	•	•	•	•	•	•	•
3 MM thru 12 MM	200M-312L		•	•	•	•	•	•	•				
5 MM thru 12 MM	200MSS-512L					•	•	•	•				
<b>THIN WALL</b>													
5 MM thru 12 MM	200MTW-512L					•	•	•	•	•			

D = Add letter "D" to assortment part number and get GARD MTS™ drill bits for given sizes (Steel and Aluminum installations) - Eliminate the letter "L" for half package quantity.

12 GARDSERTS™

02/2014

## Drill Reference Chart - Large GARDSERT™ Sizes



Internal Thread Size and Pitch	GARDSERT™ Part No.	Outside Diameter and Length	Pilot Hole Size & Drill Part No.	Installation Socket
7/8-9	C-1400-200	1.25 x 1.3125	1-3/16 (Part No. 30-19)	NA
7/8-14	F-1400-200	1.25 x 1.3125	1-3/16 (Part No. 30-19)	NA
7/8-14 (MH)	F-1400-200MH	1.375 x 1.250	1-19/64 (GSD-S1400-MH)	NA
1-8	C-1600-200	1.50 x 1.50	1-7/16 (Part No. 30-23)	NA
1-14	F-1600-200	1.50 x 1.50	1-7/16 (Part No. 30-23)	NA
1-14 (M)	F-1600-200M	1.50 x 1.375	1-7/16 (Part No. 30-23)	NA
1-1/8-7	C-1800-200	1.750 x 1.688	1-11/16 (Part No. 5241-27-12)	NA
1-1/4-7	C-2000-200	1.750 x 1.875	1-11/16 (Part No. 5241-27-12)	NA
1-1/4-12	F-2000-200	1.750 x 1.875	1-11/16 (Part No. 5241-27-12)	NA
1-3/8-6	C-2200-200	1.950 x 2.00	1-7/8 (Part No. 5241-30-12)	NA
1-1/2-6	C-2400-200	2.250 x 2.126	2-3/16 +.010/-.000	NA
M22 x 2.5	M22-200	1.25 x 1.3125	1-7/32 (Part No. 30-195)	NA
M24 x 3.0	M24-200	1.50 x 1.50	1-7/16 (Part No. 30-23)	NA
M30 x 3.5	M30-200	1.750 x 1.875	1-11/16 (Part No. 5241-27-12)	NA

**MATERIAL: Hardened 400 Series Stainless Steel**  
**GARD Deluxe Tapping Fluid is REQUIRED in all installations.**

**\*Note: Because the hole size is larger than 2 inches, the customer is responsible for the method by which to achieve the holes. For this reason, GARD Specialists only provides the specifications and tolerances to which the holes are to be bored. If further assistance is required, please contact Technical Assistance at 1-800-541-9301.**



## 8 Thread GARDSERTS™ For the Power Generation Industry

Internal Thread Size and Pitch	GARDSERT™ Part No.	Outside Diameter and Length	Pilot Hole Size & Drill Part No.	Installation Socket	Installation Tool
1-8	C-1600-200	1.50 x 1.50	1-7/16 (Part No. 30-23)	NA	200M-1608T
1-1/8-8	8-1800-200	1.50 x 1.675	1-7/16 (Part No. 30-23)	NA	200M-1808T
1-1/4-8	8-2000-200	1.75 x 1.875	1-11/16 (Part No. 5241-27-12)	NA	200M-2008T
1-3/8-8	8-2200-200	1.950 x 2.00	1-7/8 (Part No. 5241-30-12)	NA	200M-2208T
1-1/2-8	8-2400-200	2.25 x 2.126	2-3/16 +.010/-.000*	NA	200M-2408T
1-3/4-8	8-2800-200	2.50 x 2.625	2-3/8 +.010/-.000*	NA	200M-2808T
2-8	8-3200-200	2.75 x 3.00	2-5/8 +.010/-.000*	8-3200-200 Socket	NA
2-1/4-8	8-3600-200	3.00 x 3.375	2-29/32 +.010/-.000*	8-3600-200 Socket	NA
2-1/2-8	8-4000-200	3.50 x 3.750	3-11/32 +.020/-.000*	Included in tool	200M-4008T*
2-3/4-8	8-4400-200	3.75 x 4.125	3-19/32 +.020/-.000*	8-4400-200 Socket	NA
3-8	8-4800-200	4.00 x 4.50	3-13/16 +.020/-.000*	8-4800-200 Socket	NA

\*Note: Because the hole size is larger than 2 inches, the customer is responsible for the method by which to achieve the holes. For this reason, GARD Specialists only provides the specifications and tolerances to which the holes are to be bored. If further assistance is required, please contact Technical Assistance at 800-541-9301.

Be sure to use high-strength cap screw for installation.

(Note: For very large GARDSERTS™, a special socket is required instead of the usual cap screw and nut.)

The pilot-hole sizes listed above are for both Ferrous and Non-Ferrous applications.

GARD Deluxe Tapping Fluid (Part No. 5906-DTF-8) is REQUIRED for installation of all large GARDSERTS™.



Note: Part No. 200M-4008T consists of a socket, slug and F-911 capscrew. Special instructions are included with each shipment



**GARD PIPESERT™**  
**For Hydraulic / Pneumatic**  
**SIZE: Pipe Thread**  
**MATERIAL: Stainless Steel**



- PIPESERT™, GARD's revolutionary pipe thread repair system
- Simple and easy two-step installation
- The PIPESERT™ is to be considered a permanent thread repair
- The PIPESERT™ is manufactured from heat treated stainless steel, therefore, providing stronger than stock threads with the added benefit of corrosion resistance
- Unlike coil type inserts, GARD's PIPESERT has solid sleeve construction to provide greater strength and sealing ability
- The internal threads of the PIPESERT are machined to strict NPTF standards
- Wide variety of applications: HYDRAULIC, PNEUMATIC, ENGINE REPAIR, TRANSMISSION REPAIR, MACHINE TOOL APPLICATIONS and others
- Maximum operating pressure 10,000 PSI

Note: Special E.M.D. 567/645 Cylinder Head Engine Repair installation tool (Part No. 200M-P800ET) and instructions are available upon request.

NPTF Thread	PIPESERT™ Part No.	Length x O.D.	Drill Size Part No.	Counter Bore	Install Tool Part No.	3 each Boxed Kit Includes Drill Bit, Fluid and Tool	Torque Values**	
							MM	FT.LB
1/8-27	P-200-200	.550 x 9/16	17/32 (Part No. 30-085)		200M-P200T	500-P200	11-12	8-9
1/4-18	P-400-200	.750 x 5/8	23/32 (Part No. 30-115)		200M-P400T	500-P400	25-28	18-20
3/8-18	P-600-200	.821 x 7/8	53/64 (Part No. 30-133)		200M-P600T	500-P600	41-48	30-35
1/2-14	P-800-200	.944 x 1-1/8	1-3/32 (Part No. 30-175)		200M-P800T	500-P800	72-82	55-60
3/4-14	P-1200-200	1.050" x 1-3/8	1-5/16 x 1.125 Deep (Part No. 30-21)	1-3/8 x 3/16 Deep (Part No. 30-22)	200M-P1200T	500-P1200	124-137	90-100
1-1/2-11-1/2	P-2400-200	2.400"	2-5/16 (+.010/-0.000)	Counter sink hole to 1.5626" Diameter (Part No. 199-08235-82)	P-2400-200-Socket		261-275	140-200

**IMPORTANT: Thread Locking Fluid, Part No. 5905-TLF-10ML is required and should be ordered separately when purchasing individual sizes. \*\*\* DO NOT SUBSTITUTE \*\*\***

\*\*Torque fittings to these specs

Note: Thread Locking Fluid, Part No. 5905-TLF-10ML, is included in all kits and assortments

**Pipesert™**  
**Assortments**  
**in Custom**  
**Steel Tray**



**Part No. 200-P28LD**

4 Pieces each size above 1/8-1/2 NPT, Install Tools, Thread Lock Fluid and Drill Bits with Deluxe Tapping Fluid in a custom burgundy steel tray

**Part No. 200-P212LD**

4 Pieces each size above 1/8-3/4 NPT, Install Tools, Thread Lock Fluid and Drill Bits with Deluxe Tapping Fluid in a custom burgundy steel tray

**Part No. 200-P28L**

4 Pieces each size above, 1/8-1/2 NPT, Install Tools, Thread Lock Fluid in a custom burgundy steel tray

**Part No. 200-P212L**

4 Pieces each size above, 1/8-3/4 NPT, Install Tools, Thread Lock Fluid in a custom burgundy steel tray

**GARDSERTS™ 15**

## GARD PIPESERT™

### GARD PIPESERT™ INSTALLATION

You will need: the appropriate DRILL BIT, GARD PIPESERT™ Installation Tool for the PIPESERT™ (from the chart on page 16) and a bottle of Thread Locking Fluid PART NO. 5905-TLF-10ML.

- 1) Drill out damaged threads with the appropriate drill bit.
- 2) Assemble the PIPESERT™ Installation tool as follows:  
Place one (1) hardened flat washer onto the special cap screw; (2) are needed for the 3/8-18 PIPESERT™  
Next, place the oversized hex nut onto the assembly  
Follow with (1) hardened flat washer  
Apply a lubricant (such as GARD Deluxe Tapping Fluid, Part No. 5906-DTF-8, or an anti-seize compound) to the threads of the cap screw, thread the PIPESERT™ on.  
Make sure that the slot end is first to enter the hole when installing the PIPESERT™.



- 3) Apply a liberal coating of the Thread Lock Fluid (Part No. 5905-TLF-10ML)\* to the *outside* threads of the PIPESERT™ before installation. Carefully align the PIPESERT™ to the hole. Turn the PIPESERT™ into the hole clockwise using a wrench or socket and impact wrench on the hex head cap screw of the INSTALLATION TOOL. Turn the PIPESERT™ into the work piece until the top of the PIPESERT™ is flush with the top surface of the work piece.

**\*CAUTION! DO NOT SUBSTITUTE THE SUPPLIED THREAD LOCK WITH ANY OTHER COMPOUND**

- 4) When the PIPESERT™ is fully installed, hold the oversize nut stationary and apply reverse torque to the hex head cap screw, allowing the hex head cap screw to rotate out of the PIPESERT™. This allows the tool to disengage from the PIPESERT™.
- 5) Reverse the PIPESERT™ INSTALLATION TOOL completely from the PIPESERT™ and you have accomplished the repair.

## IMPORTANT!

**ALLOW 24 HOURS CURE TIME FOR THE THREAD LOCK TO SET BEFORE SUBJECTING THE REPAIR TO PRESSURE OR FLUIDS**

## **Spark Plug / O<sup>2</sup> Sensor GARDSERT™**

**PURPOSE: Spark Plugs / O<sup>2</sup> Sensors**

**MATERIAL: Steel / Stainless Steel**



**Unique “Long Reach” SP-14MM12-200 fits all major 14 MM x 19MM spark plug styles; gasket and taper seat, full and partial thread.**

### **Features and Benefits**

- Easy to install, just drill the pilot hole and screw in the long reach **SPARK PLUG GARDSERT™**
- Solid heat treated stainless steel
- Unique design fits all major styles of long reach 14 mm spark plugs (gasket seat and taper seat, full and partial thread)
- Special design makes it nearly impossible to “cross-thread” a spark plug (a major cause of spark plug thread damage)
- Great reliability, considered to be permanent thread repair
- High performance, unlike coil type inserts, **GARD’s** long reach **SPARK PLUG GARDSERT™** has solid sleeve construction to provide greater strength and sealing ability
- The long reach **SPARK PLUG GARDSERT™** is manufactured from heat treated stainless steel, therefore, providing stronger than “stock” threads with added benefit of corrosion resistance
- Wide variety of applications: automobile, light truck, snowmobiles, A.T.V.s, marine applications and others . . .

## Spark Plug / O<sup>2</sup> Sensor GARDSERT™ (cont.)



Thread x Length	GARDSERT™ Part No.	Drill Size (Part No.)	Use Thread Lock Fluid (Yes or No)	Boxed Kit 8 ea. 14MM or 4 ea. 18MM Drill Bit and Fluid
14 MM x 3/8	SP-14MM06-200	21/32 (30-105)	No	500-SP1406-200
14 MM x 3/4	SP-14MM12-200	23/32 (30-115)	Yes	500-SP1412-200
14 MM x 3/4	SAME AS 500-SP1412-200 WITH 12" OAL. DRILL			500-SP1412LD-200
18 MM x 25/64	SP-18MM07-200	7/8 (30-14)	Yes	500-SP1807-200

**AUTO REPAIR KIT:** 14MM Long Reach and (4) pieces 18MM, Drill bits and Thread Lock Fluid, cardboard boxed. **Part No. 500-SP1418-200**

### Spark Plug / O<sup>2</sup> Sensor GARDSERT™ INSTALLATION

- 1) Remove worn threads in the engine spark plug port(s) with the appropriate size drill bit. Part No. **30-105 (21/32")** for **SP-14MM06-200**; **30-115 (23/32")** for **SP-14MM12-200** and **30-14 (7/8")** for **SP-18MM07-200**. Make sure chips do not enter the cylinder.
- 2) For SP-14MM12-200 and SP-18MM07-200, use the spark plug O<sup>2</sup> sensor that you intend to leave in the engine as the installation tool. PROCEED TO STEP 3.
- 2b) For the SP-14MM06-200, shorten a discarded spark plug which will become an installation tool. (A spark plug with a thin metal washer or gasket is preferred). Cut the tip back enough to prevent blockage of the three tapping holes in the **GARDSERT™** when the insert and spark plug are mated. Recommendation: **GARD ThinFlex™** cutoff wheels make short work of this modification.
- 3) Thread the **GARDSERT™** onto the installation tool. Apply a liberal coating of GARD Thread Locking Fluid (Part No. 5905-TLF-10ML) to the **outside of the GARDSERT™** and the **wall of the hole in the cylinder head**, and turn into spark plug port, **maintaining proper alignment**. Let sit 24 hours. FINISHED.
- 3b) (**SP-14MM06-200 ONLY**) Once the **GARDSERT™** is installed, remove the altered spark plug, saving it for future use. Trust that your re-assembled engine now has new, stronger, spark plug threads.



## EMD ENGINE GARDSERT™ Block Repair

Assortment Part No. 200-EMD - 136 pieces in steel tray

### Accessory End of Block

	Size/Thread	Length	GARD Part No.	Kit Qty.	Drill Size
Lay shaft support arm	1/2 - 20	.75	F-800-200M	25	45/64"
Fuel block mounting					
Upper half accessory end housing					
Over- speed housing					
Water manifold					
Oil manifold					

### Top Deck Frame

	Size/Thread	Length	GARD Part No.	Kit Qty.	Drill Size
Top Deck Frame	3/8 - 24	.687	F-600-200 Std. Wall	50	17/32"
P-Pipe	5/16 - 24	.562	F-500-200TW Thin Wall	25	"W"
Cam Supports	1/2 - 20	.75	F-800-200M	see above	45/64"
Stack Bolt Holes	5/8 - 18	.9375	F-1000-200M	25	55/64"
Lifting Pad Bolt Holes	1" - 14	1.50	F-1600-200	3	1-7/16"

## EMD ENGINE TURBO (rear) GARDSERT™ Repair

	Size/Thread	Length	GARD Part No.	Kit Qty.	Drill Size
Bottom of Housing	3/4 - 16	.812	F-1200-200S	6	1-1/32"
Upper Turbo Housing	1/2 - 20	.75	F-800-200M	see above	45/64"
710 Block or Stub Shaft	5/8 - 18	.9375	F-1000-200M	see above	55/64"
Stub Shaft	7/8 - 14	1.25	F-1400-200MH Heavy Wall	2	1-19/64"
Oil Manifold	3/8 - 24	.687	F-600-200	50	17/32"

This is not a complete **GARDSERT™** usage listing, there are many more applications:

**After-Coolers** (Radiators)  
and **Oil-Coolers** will use a:

3/8" coarse (USS)  
3/8" fine (SAE)  
1/2" coarse (USS)

**Part No. C-600-200**  
**Part No. F-600-200**  
**Part No. C-800-200**

**Alternator Lift Pad Bolts** will use a:

1"-14 fine (SAE)

**Part No. F-1600-200**

**G.E. Roof Mount A.C. Units** will use a:

1/2" coarse (USS)

**Part No. C-800-200**

# GARD PIPESERT™ Installation Instructions

## EMD 567/645 Cylinder Head Repair

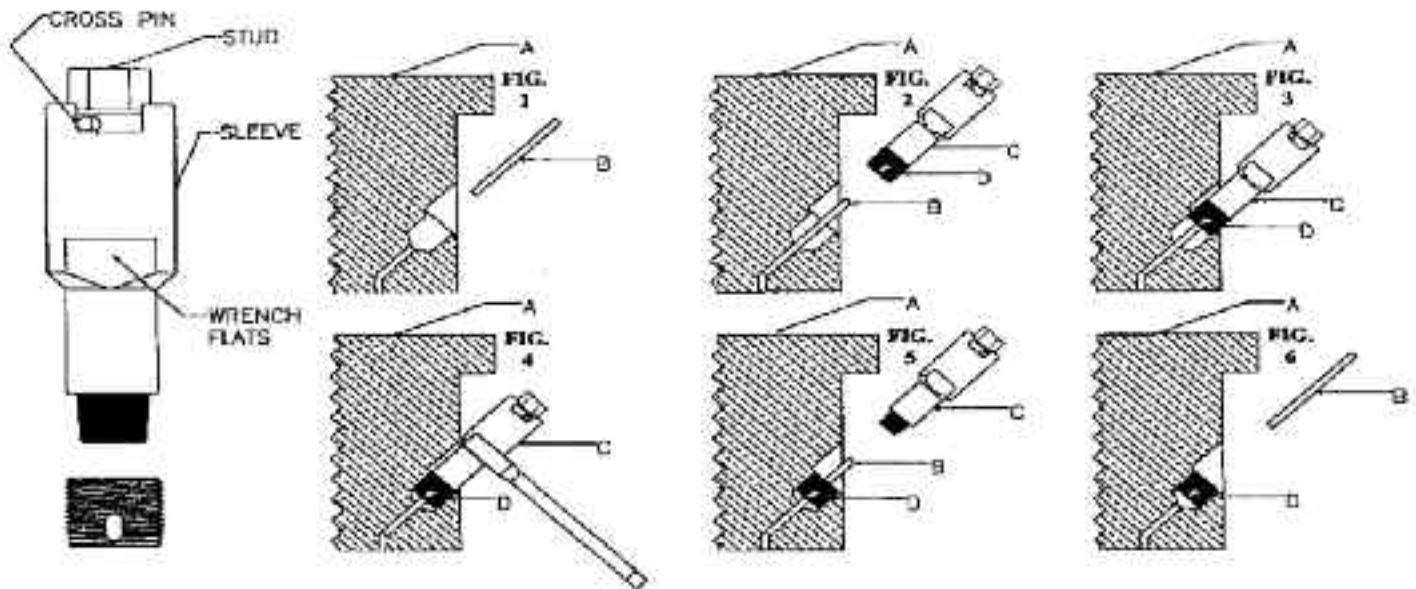

## GARD PIPESERT™ Engine Installation

You will need: a 1-3/32" Drill Bit (Part No. 30-175), **GARD PIPESERT™ Installation Tool** (Part No. 200M-P800ET) for the **PIPESERT™** and tube of **Thread Lock** (required for each **PIPESERT™** install) a 1/2" or greater capacity drill motor and a 1-1/16" open end wrench.

1) Drill out the damaged threads with a 1-3/32" drill bit.

2) Take the **PIPESERT™ Installation Tool** in hand. Holding it by the sleeve, rotate the stud clockwise so that the cross pin is at its forward position. Thread a **PIPESERT™** onto the tool until it stops. The assembly should now look like the one in the drawing above. At this point you are ready for installation.

**Fig. 1)** Insert the **Guide Rod B** (Part No. 200M-P800ET-ROD) into the port in the **Cylinder Head A**.

**Fig. 2)** Apply a liberal coating of the **Thread Lock** supplied with your **PIPESERT™ D** to the outside threads of the **PIPESERT™ D** before installation. *Carefully align the PIPESERT™ / Insert Tool Assembly C* to the hole and **Guide Rod B**.

**Fig. 3)** Turn the **PIPESERT™ D / Installation Tool C** assembly into the hole clockwise using a wrench, or socket and impact wrench, on the hex of the stud on the **Installation Tool C**. Turn the **PIPESERT™ D** into the hole until the top of the **PIPESERT™ D** is flush with the top surface of the hole.

**Fig. 4)** When the **PIPESERT™ D** is fully installed, secure the **Sleeve** of the **Installation Tool C** with a 1-1/16" **Open end Wrench**, and apply reverse torque to the hex drive on the **Installation Tool C** allowing the **Cross Pin** to rotate to its reverse position. A gap between the bottom of the **Sleeve** of the **Installation Tool C** and the top surface of the **PIPESERT™ D** is formed, allowing the tool to disengage itself from the **PIPESERT™ D**.

**Fig. 5)** *Withdraw the wrench* and un-thread the **Installation Tool C** completely from the **PIPESERT™ D**.

**Fig. 6)** Remove the **Guide Rod B** from the port **Cylinder Head A** and you have accomplished the repair.

**IMPORTANT:** Please allow 24 hours cure time for the thread lock to set before subjecting to pressures or fluids.



## Brass GARDSERTS™

For Wood and Plastics

SIZE: Fractional

MATERIAL: Solid Brass



**BRASS GARDSERTS™ for wood can be used in hard or soft woods, the coarse external self-cutting thread provides both strength and the ability to be installed without splitting the wood. Once properly installed, Wood GARDSERTS™ will not back out.**

**As Plastic material densities vary, try testing a small area with a sharp knife. If you can achieve shaving a curl, the BRASS GARDSERT™ will install successfully, slot down.**

**If the plastic is difficult to carve, use Regular GARDSERTS™ on page 5.**

Internal Thread Size and Pitch	For Wood or Plastic GARDSERT™ Part No.	Length	External Diameter and Threads Per Inch	Installation Drill Size (Part No.)
#4-40	440-200B	.344	7/32-11	11/64 (Part No. 30-028)
#6-32	632-200B	.344	7/32-11	11/64 (Part No. 30-028)
#8-32	832-200B	.406	1/4-11	13/64 (Part No. 30-033)
#10-24	1024-200B	.469	19/64-9	"B" (Part No. 34-B)
#10-32	1032-200B	.469	19/64-9	"B" (Part No. 34-B)
1/4-20	C-400-200B	.500	3/8-9	5/16 (Part No. 30-05)
1/4-20 (Large O.D.)	C-400-200BL	.500	15/32-9 (Large O.D.)	3/8 (Part No. 30-06)
5/16-18	C-500-200B	.500	15/32-9	3/8 (Part No. 30-06)
5/16-18 (Large O.D.)	C-500-200BL	.500	9/16-9(Large O.D.)	15/32 (Part No. 30-075)
3/8-16	C-600-200B	.938	9/16-6	15/32 (Part No. 30-075)

**ASSORTMENTS:** Part Number: 200B-406CXL  
Includes 25 pieces each size listed above packaged in a heavy duty steel tray.

Part Number: 200B-406CXLD  
Includes Drill Bits and 25 pieces each size listed above packaged in a heavy duty steel tray.

### BRASS GARDSERT™ INSTALLATION

**For medium to hard wood and plastic:**

Start Wood GARDSERT™ slot down. Turn in Wood GARDSERT™ with a common screw that matches internal thread, using a hex nut as a stop and a wrench to turn in the Wood GARDSERT™.

**For soft wood:**

Start Wood GARDSERT™ slot up. Screw in with a flat head screwdriver.



## **GARD MTS™ Drill Bit Sets for GARDSERT™ Installations**

**Choose the material that the GARDSERT™ is being installed into:  
Steel, Aluminum or Both**



<b>Size Range of GARDSERTS™</b>	<b>Installing In</b>	<b>Part No.</b>
1/4-3/8 Brass	Wood / Plastic	200D-406B-W
1/4-1/2 Standard	Aluminum	200D-408-A
1/4-1/2 Standard	Steel	200D-408-S
1/4-1/2 Thin Wall	Aluminum	200D-408TW-A
1/4-1/2 Thin Wall	Steel	200D-408TW-S
1/4-3/4 Standard	Steel and Aluminum	200D-412
1/4-3/4 Standard	Aluminum	200D-412-A
1/4-3/4 Standard	Steel	200D-412-S
#6 thru 3/8 Standard	Aluminum	200D-606-A
#6 thru 3/8 Standard	Steel	200D-606-S
#6 thru 1/2 Standard	Aluminum	200D-608-A
#6 thru 1/2 Standard	Steel	200D-608-S
#6 thru 3/4 Standard	Aluminum	200D-612-A
#6 thru 3/4 Standard	Steel	200D-612-S
3 MM thru 12 MM Standard	Aluminum	200D-M312-A
3 MM thru 12 MM Standard	Steel	200D-M312-S
3 MM thru 18 MM Standard	Aluminum	200D-M318-A
3 MM thru 18 MM Standard	Steel	200D-M318-S
5 MM thru 12 MM Thin Wall	Aluminum	200D-M512TW-A
5 MM thru 12 MM Thin Wall	Steel	200D-M512TW-S

**Do you need an assortment that is not listed? Just call and we will create one for you.**

## GARDSERT™ Installation Tools

**Includes Hardened Cap Screw, Hardened Hex Nuts and Hardened Flat Washers for both manual and power install.**



Thread Size	GARDSERT™ Part No.	Installation Tool Part No.
2-56	256-200	200M-256T
4-40	440-200	200M-440T
6-32	632-200	200M-632T
8-32	832-200	200M-832T
10-24	1024-200	200M-1024T
10-24	1024-200TW	200M-1024T
10-32	1032-200	200M-1032T
10-32	1032-200TW	200M-1032T
1/4-20	C-400-200	200M-420T
1/4-20	C-400-200TW	200M-420T
1/4-28	F-400-200	200M-428T
1/4-28	F-400-200TW	200M-428T
5/16-18	C-500-200	200M-518T
5/16-18	C-500-200TW	200M-518T
5/16-24	F-500-200	200M-524T
5/16-24	F-500-200TW	200M-524T
3/8-16	C-600-200	200M-616T
3/8-16 (M)	C-600-200M	200M-616MT
3/8-16	C-600-200TW	200M-616T
3/8-24	F-600-200	200M-624T
3/8-24	F-600-200TW	200M-624T
7/16-14	C-700-200	200M-714T
7/16-14	C-700-200TW	200M-714T
7/16-20	F-700-200	200M-720T
7/16-20	F-700-200TW	200M-720T
1/2-13	C-800-200	200M-813T
1/2-13 (S)	C-800-200S	200M-813ST
1/2-13	C-800-200TW	200M-813T
1/2-20	F-800-200	200M-820T
1/2-20	F-800-200TW	200M-820T
9/16-12	C-900-200	200M-912T
9/16-18	F-900-200	200M-918T
5/8-11	C-1000-200	200M-1011T
5/8-18 (M)	F-1000-200M	200M-1018T
5/8-18	F-1000-200	200M-1018T
3/4-10	C-1200-200	200M-1210T
3/4-16 (S)	F-1200-200S	200M-1216ST
3/4-16 (M)	F-1200-200M	200M-1216MT
3/4-16	F-1200-200	200M-1216T



## GARDSERT™ Installation Tools (cont.)



All install tools for a	200-412CL Assortment	500-412CT in a metal tray
All install tools for a	200-612CFL Assortment	500-612CFT in a metal tray
7/8-9	C-1400-200	200M-1409T
7/8-14 (M)	F-1400-200MH	200M-1414MT
7/8-14	F-1400-200	200M-1414T
1-8	C-1600-200	200M-1608T
1-14 (M)	F-1600-200M	200M-1614MT
1-14	F-1600-200	200M-1614T
1-1/8-7	C-1800-200	200M-1807T
1-1/4-7	C-2000-200	200M-2007T
1-1/4-12	F-2000-200	200M-2012T
1-3/8-6	C-2200-200	200M-2206T
<b>Metric</b>	<b>GARDSERT™ Part No.</b>	<b>Installation Tool Part No.</b>
M3 X .5	M3-200	200M-M305T
M3.5 X .6	M3.5-200	200M-M3.506T
M4 X .7	M4-200	200M-M407T
M5 X .8	M5-200	200M-M508T
M5 X .8	M5-200TW	200M-M508T
M6 X 1.0	M6-200	200M-M610T
M6 X 1.0	M6-200TW	200M-M610T
M8 X 1.25	M8-200	200M-M8125T
M8 X 1.25	M8-200TW	200M-M8125T
M10 X 1.5	M10-200	200M-M1015T
M10 X 1.25	M101.25-200TW	200M-M10125T
M10 X 1.5	M10-200TW	200M-M1015T
M12 X 1.50	M121.50-200	200M-M12150T
M12 X 1.75	M12-200	200M-M12175T
M12 X 1.75	M12-200TW	200M-M12175T
M14 X 2.0	M14-200	200M-M14200T
M16 X 2.0	M16-200	200M-M1620T
M18 X 2.5	M18-200	200M-M1825T
M20 X 2.5	M20-200	200M-M2025T
M22 X 2.5	M22-200	200M-M2225T
M24 X 3.0	M24-200	200M-M2430T
M30 X 3.5	M30-200	200M-M3035T
<b>NPTF Thread</b>	<b>PIPESERT™ Part No.</b>	<b>Installation Tool Part No.</b>
1/8-27 NPTF	P-200-200	200M-P200T
1/4-18 NPTF	P-400-200	200M-P400T
3/8-18	P-600-200	200M-P600T
1/2-14	P-800-200	200M-P800T
3/4-14	P-1200-200	200M-P1200T

## GARDSERT™ Technical Information

### Applications, Certifications and Approvals:

- US Military- Approval, NSN assignment
- MSHA - Test
- ABS - Certification
- ETL - Testing for FAA ground fixtures
- Froehling & Robertson - Testing for proof load
- Railroad Industry
- Power Generation
- Food Processing
- All Heavy Industrial Maintenance
- Automotive Industry

## PULL-OUT STRENGTH

**Note: Testing is based on 303 Stainless Steel, not 400 series**

Fractional	Installed GARDSERT™ Pull-out Strength						Thin Wall
Nominal Size Internal Thread	Effective Shear Area Sq. Inch	Paper Base Bakelite Approx. 9,700 PSI Shear	Cast Aluminum 356T6 26,000 PSI Shear	Wrought Aluminum 2024T4 40,000 PSI Shear	Cast Magnesium EZ33AT5 16,000 PSI Shear	Cast Magnesium AMS4434T6 AMS4490T6 20,000 PSI Shear	Cast Magnesium AMS4424T6 21,000 PSI Shear
#4	.053	630	1380	2150	825	1060	1120
#6	.081	775	2140	3240	1295	1620	1700
#8	.111	1080	2880	4440	1752	2220	2320
#10	.148	1400	3804	5900	2365	2960	3650
1/4"	.247	2400	6350	9840	3945	4940	5390
5/16"	.352	3400	9200	14130	5515	7040	7400
3/8"	.531	5100	13750	21200	8450	10600	11190
7/16"	.690	6600	17910	27600	11200	13800	14500
1/2"	.930	9200	24200	37000	14900	18600	19500



**FROEHLING & ROBERTSON, INC**  
GEOTECHNICAL • ENVIRONMENTAL • MATERIALS  
ENGINEERS • LABORATORIES  
"OVER ONE HUNDRED YEARS OF SERVICE"  
3015 Dumbarton Road  
Richmond, Virginia 23228  
Telephone (804) 264-2701 Fax (804) 264-3546

December 14, 2004

**REPORT OF PROOFLOAD TESTS**

TEST DATES: December 6 &amp; 13, 2004

PROJECT NO.: F60-0612M

CLIENT: GARD Specialists Co. Inc.  
PO BOX 157  
Eagle River WI 54521

REPORT NO.: 1

PROJECT: GARDSERT Proofload Tests

On the referenced dates, an F&R technician conducted proofload tests on assemblies supplied by the client's representative. Samples were tested in tension in a Baldwin Tate-Emery Universal Testing Machine calibrated in accordance with NIST requirements in June 2004.

## Materials supplied;

Hex head cap screws (GARD F-911), 4140 modified alloy steel  
1/4-20 x 2" batch #29293  
1/2-13 x 2-1/2" batch #30122  
3/4-10 x 3" batch #29388

GARDSERTS, AISI 420 stainless steel

Plates for inserts  
ASTM A312, Type 304  
ASTM A312, Type 316  
ASTM A36

Attached documents indicate the test parameters accomplished and the results of the tests. Should you have any questions or require additional information, please contact our office.

Respectfully submitted,  
**FROEHLING & ROBERTSON, INC.**

Brett D. Clarke  
Metals/NDT Department Manager



**1/4" Hex Cap Screw in A312, Type 316 Plate**

After bolt failure, remaining bolt segment was removed by hand, with no insert thread deformation

Screw Size	Base Material	Load, Lbs.	Load, PSI	Failure Mode
1/4"	A36	3,960	80,700	Insert pulled from plate
1/4"	A312, type 316	5,400	110,000	Bolt fracture



**1/2" Hex Cap Screw in A312, Type 304 Plate**

After bolt failure, remaining bolt segment was removed by hand, with no insert thread deformation

Screw Size	Base Material	Load, Lbs.	Load, PSI	Failure Mode
1/2"	A36	27,100	138,000	Bolt fracture
1/2"	A312, type 304	24,500	124,800	Test guide failure



**3/4" Hex Cap Screw in A36**

After bolt failure, remaining bolt segment was removed by hand, with no insert thread deformation

Screw Size	Base Material	Load, Lbs.	Load, PSI	Failure Mode
3/4"	A36	62,000	140,300	Bolt fracture
3/4"	A312, type 316	63,000	142,600	Bolt fracture

## **Airport Runway Lighting Base Can Top Flange Repair Kit**

Part Number: 200-AW7012G-2  
Fits Jaquith models 867B / 868B



- Make repairs quickly and accurately
- Remove broken bolts
- Replace damaged bolt hole threads
- Dual bolt pattern – 867B and 868B
- GARD Specialists Co., Inc. drill fixture ring assures proper alignment with existing bolt pattern
- No need to remove spacer rings
- Install the GARDSERT™ – 400 series stainless steel and harder than the 18/8 flange bolt

### **Base Can Drill Fixture Kit with GARDSERT™**

- Drill fixture ring for alignment with existing bolt pattern
- Dual bolt pattern for L867B and L868B
- Just remove the light fitting - works through spacer rings
- Steel “Mad-Plate” supplied for use with magnetic drills
- Hardened bushings for precision guidance
- MTS Drill Bits remove broken bolts
- Reamer for clearance
- Custom installation tool
- 3/8” - 16 Stainless Steel TW GARDSERT™ to repair threaded holes (25 ct.PN.C-600-200TW)
- GARDSERT™ FAA approved Independent third party certification
- Deluxe Tapping Fluid



### **Airport Runway Lighting Base Can Top Flange Repair Kit**

See instructions on pages 29-31



**FAA Approved**



## Airport Runway Lighting Base Can Top Flange Repair Kit (cont.)

**Part Number: 200-AW7012G-2**  
**Fits Jaquith models 867B / 868B**

### Repair top flange threaded hole:

Remove light fitting and install drill fixture ring using proper fasteners. (867B or 868B)



Cut away for illustration purposes only.



The drill fixture ring is shown here installed on an extension and is elevated for illustration purposes only.

**Step 1)** Install the 15/32" bushing in the fixture. Use 15/32" drill bit and drill through spacer rings, flange and/or the top flange.

**Step 2) If there are NO spacer rings and/or flange ring, go to Step 3.**

Measure the total depth of the flange ring and/or spacer rings and set the depth (\*see note) for the reamer using the stop collar. Install the 1/2" bushing. Use 1/2" chucking reamer to enlarge all of the 7/16" through holes in flange ring and/or spacer rings.



Depth for stop collar.

**STOP** before the top flange.  
**DO NOT** use the reamer to enlarge the hole in the base can flange.

**3)** Assemble the **GARDSERT™** installation tool as shown.



The installation sleeve outside diameter is slightly larger than the GARDSERT™. This assures that the GARDSERT™ will be installed flush with the top flange.



## **Airport Runway Lighting Base Can Top Flange Repair Kit (cont.)**

**Part Number: 200-AW7012G-2  
Fits Jaquith models 867B / 868B**

### **Repair top flange threaded hole (cont.)**

**Step 4) Generously apply Deluxe Tapping Fluid to the GARDSERT™ and the drilled hole. Allow some of the tapping fluid to flow down into the hole in the top flange.**

Insert the **GARDSERT™** installation tool assembly into the bushing.



**Step 5) Place a wrench on the cap screw and turn the GARDSERT™ assembly until the tool bottoms out and the GARDSERT™ is installed flush with the top flange. Place a second wrench on the hex nut to hold it and reverse the direction of cap screw to break the tension between the assembly and the GARDSERT™.**



**Step 6) Remove chips from GARDSERT™ using tube brush. Remove drill fixture and reinstall light fitting.**



**GARDSERT™  
Won't wear out . . .  
Won't pull out . . .  
400 series stainless steel**

## **Airport Runway Lighting Base Can Top Flange Repair Kit (cont.)**

**Part Number: 200-AW7012G-2  
Fits Jaquith models 867B / 868B**

### **Remove broken bolt from GARDSERT™**

Because GARDSERT™ is harder than the 18/8 bolt, you may be able to turn out the broken stud. If you cannot grasp the broken stud, follow these procedures.

Remove light fitting and install drill fixture ring using proper fasteners.

(867B or 868B)



The drill fixture ring is shown here installed on an extension and is elevated for illustration purposes only.

Install the 1/4" bushing in the fixture. Use 1/4" drill bit and drill through the bolt. Remove the drill fixture ring. If the bolt hole is not clear, use the screw extractor and remove the broken stud.

